

LMV321/LMV358/LMV324 Single/Dual/Quad General Purpose, Low Voltage, Rail-to-Rail Output Operational Amplifiers

General Description

The LMV358/LMV324 are low voltage (2.7–5.5V) versions of the dual and quad commodity op amps, LM358/LMV324, which currently operate at 5–30V. The LMV321 is the single version.

The LMV321/LMV358/LMV324 are the most cost effective solutions for the applications where low voltage operation, space saving and low price are needed. They offer specifications that meet or exceed the familiar LM358/LMV324. The LMV321/LMV358/LMV324 have rail-to-rail output swing capability and the input common-mode voltage range includes ground. They all exhibit excellent speed to power ratio, achieving 1 MHz of bandwidth and 1 V/ μ s of slew rate with low supply current.

The LMV321 is available in the space saving 5-Pin SC70, which is approximately half the size of the 5-Pin SOT23. The small package saves space on PC boards, and enables the design of small portable electronic devices. It also allows the designer to place the device closer to the signal source to reduce noise pickup and increase signal integrity.

The chips are built with National's advanced submicron silicon-gate BiCMOS process. The LMV321/LMV358/LMV324 have bipolar input and output stages for improved noise performance and higher output current drive.

Features

(For $V^+ = 5V$ and $V^- = 0V$, unless otherwise specified)

- Guaranteed 2.7V and 5V performance
- No crossover distortion
- Space saving package 5-Pin SC70 2.0x2.1x1.0 mm
- Industrial temperature range $-40^{\circ}C$ to $+85^{\circ}C$
- Gain-bandwidth product 1 MHz
- Low supply current
 - LMV321 130 μ A
 - LMV358 210 μ A
 - LMV324 410 μ A
- Rail-to-rail output swing @ 10 k Ω
 - $V^+ - 10$ mV
 - $V^- + 65$ mV
- V_{CM} $-0.2V$ to $V^+ - 0.8V$

Applications

- Active filters
- General purpose low voltage applications
- General purpose portable devices

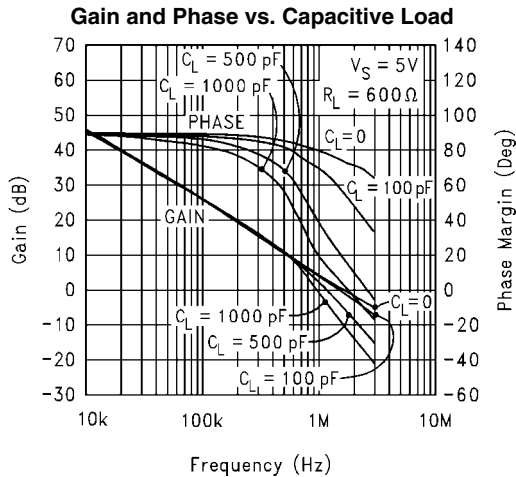

10006045

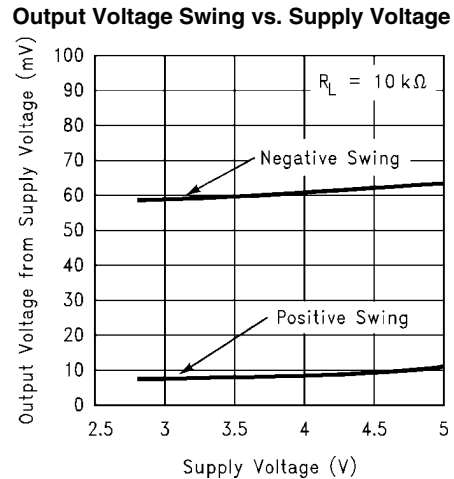

10006067

Absolute Maximum Ratings (Note 1)

If Military/Aerospace specified devices are required, please contact the National Semiconductor Sales Office/Distributors for availability and specifications.

ESD Tolerance (Note 2)	
Human Body Model	
LMV358/LMV324	2000V
LMV321	900V
Machine Model	100V
Differential Input Voltage	±Supply Voltage
Supply Voltage (V ⁺ -V ⁻)	5.5V
Output Short Circuit to V ⁺	(Note 3)
Output Short Circuit to V ⁻	(Note 4)
Soldering Information	
Infrared or Convection (20 sec)	235°C

Storage Temp. Range	-65°C to 150°C
Junction Temperature (Note 5)	150°C

Operating Ratings (Note 1)

Supply Voltage	2.7V to 5.5V
Temperature Range (Note 5)	
LMV321/LMV358/LMV324	-40°C to +85°C
Thermal Resistance (θ_{JA}) (Note 10)	
5-pin SC70	478°C/W
5-pin SOT23	265°C/W
8-Pin SOIC	190°C/W
8-Pin MSOP	235°C/W
14-Pin SOIC	145°C/W
14-Pin TSSOP	155°C/W

2.7V DC Electrical Characteristics

Unless otherwise specified, all limits guaranteed for $T_J = 25^\circ\text{C}$, $V^+ = 2.7\text{V}$, $V^- = 0\text{V}$, $V_{CM} = 1.0\text{V}$, $V_O = V^+/2$ and $R_L > 1\text{M}\Omega$.

Symbol	Parameter	Conditions	Min (Note 7)	Typ (Note 6)	Max (Note 7)	Units
V_{OS}	Input Offset Voltage			1.7	7	mV
TCV_{OS}	Input Offset Voltage Average Drift			5		$\mu\text{V}/^\circ\text{C}$
I_B	Input Bias Current			11	250	nA
I_{OS}	Input Offset Current			5	50	nA
CMRR	Common Mode Rejection Ratio	$0\text{V} \leq V_{CM} \leq 1.7\text{V}$	50	63		dB
PSRR	Power Supply Rejection Ratio	$2.7\text{V} \leq V^+ \leq 5\text{V}$ $V_O = 1\text{V}$	50	60		dB
V_{CM}	Input Common-Mode Voltage Range	For CMRR $\geq 50\text{ dB}$	0	-0.2		V
				1.9	1.7	V
V_O	Output Swing	$R_L = 10\text{ k}\Omega$ to 1.35V	$V^+ - 100$	$V^+ - 10$		mV
				60	180	mV
I_S	Supply Current	LMV321		80	170	μA
		LMV358 Both amplifiers		140	340	μA
		LMV324 All four amplifiers		260	680	μA

2.7V AC Electrical Characteristics

Unless otherwise specified, all limits guaranteed for $T_J = 25^\circ\text{C}$, $V^+ = 2.7\text{V}$, $V^- = 0\text{V}$, $V_{CM} = 1.0\text{V}$, $V_O = V^+/2$ and $R_L > 1\text{M}\Omega$.

Symbol	Parameter	Conditions	Min (Note 7)	Typ (Note 6)	Max (Note 7)	Units
GBWP	Gain-Bandwidth Product	$C_L = 200\text{ pF}$		1		MHz
Φ_m	Phase Margin			60		Deg
G_m	Gain Margin			10		dB
e_n	Input-Referred Voltage Noise	$f = 1\text{ kHz}$		46		$\frac{\text{nV}}{\sqrt{\text{Hz}}}$
i_n	Input-Referred Current Noise	$f = 1\text{ kHz}$		0.17		$\frac{\text{pA}}{\sqrt{\text{Hz}}}$

5V DC Electrical Characteristics

Unless otherwise specified, all limits guaranteed for $T_J = 25^\circ\text{C}$, $V^+ = 5\text{V}$, $V^- = 0\text{V}$, $V_{\text{CM}} = 2.0\text{V}$, $V_O = V^+/2$ and $R_L > 1\text{M}\Omega$.

Boldface limits apply at the temperature extremes.

Symbol	Parameter	Conditions	Min (Note 7)	Typ (Note 6)	Max (Note 7)	Units
V_{OS}	Input Offset Voltage			1.7	7 9	mV
TCV_{OS}	Input Offset Voltage Average Drift			5		$\mu\text{V}/^\circ\text{C}$
I_{B}	Input Bias Current			15	250 500	nA
I_{OS}	Input Offset Current			5	50 150	nA
CMRR	Common Mode Rejection Ratio	$0\text{V} \leq V_{\text{CM}} \leq 4\text{V}$	50	65		dB
PSRR	Power Supply Rejection Ratio	$2.7\text{V} \leq V^+ \leq 5\text{V}$ $V_O = 1\text{V}$, $V_{\text{CM}} = 1\text{V}$	50	60		dB
V_{CM}	Input Common-Mode Voltage Range	For CMRR ≥ 50 dB	0	-0.2		V
				4.2	4	V
A_v	Large Signal Voltage Gain (Note 8)	$R_L = 2\text{k}\Omega$	15 10	100		V/mV
V_O	Output Swing	$R_L = 2\text{k}\Omega$ to 2.5V	$V^+ - 300$ $V^+ - 400$	$V^+ - 40$		mV
				120	300 400	mV
		$R_L = 10\text{k}\Omega$ to 2.5V	$V^+ - 100$ $V^+ - 200$	$V^+ - 10$		mV
				65	180 280	mV
I_O	Output Short Circuit Current	Sourcing, $V_O = 0\text{V}$	5	60		mA
		Sinking, $V_O = 5\text{V}$	10	160		
I_S	Supply Current	LMV321		130	250 350	μA
		LMV358 Both amplifiers		210	440 615	μA
		LMV324 All four amplifiers		410	830 1160	μA

5V AC Electrical Characteristics

Unless otherwise specified, all limits guaranteed for $T_J = 25^\circ\text{C}$, $V^+ = 5\text{V}$, $V^- = 0\text{V}$, $V_{\text{CM}} = 2.0\text{V}$, $V_O = V^+/2$ and $R_L > 1\text{M}\Omega$.

Boldface limits apply at the temperature extremes.

Symbol	Parameter	Conditions	Min (Note 7)	Typ (Note 6)	Max (Note 7)	Units
SR	Slew Rate	(Note 9)		1		V/ μs
GBWP	Gain-Bandwidth Product	$C_L = 200\text{pF}$		1		MHz
Φ_m	Phase Margin			60		Deg
G_m	Gain Margin			10		dB
e_n	Input-Referred Voltage Noise	$f = 1\text{kHz}$		39		$\frac{\text{nV}}{\sqrt{\text{Hz}}}$
i_n	Input-Referred Current Noise	$f = 1\text{kHz}$		0.21		$\frac{\text{pA}}{\sqrt{\text{Hz}}}$

Note 1: Absolute Maximum Ratings indicate limits beyond which damage to the device may occur. Operating Ratings indicate conditions for which the device is intended to be functional, but specific performance is not guaranteed. For guaranteed specifications and the test conditions, see the Electrical Characteristics.

Note 2: Human Body Model, applicable std. MIL-STD-883, Method 3015.7. Machine Model, applicable std. JESD22-A115-A (ESD MM std. of JEDEC) Field-Induced Charge-Device Model, applicable std. JESD22-C101-C (ESD FICDM std. of JEDEC)

Note 3: Shorting output to V⁺ will adversely affect reliability.

Note 4: Shorting output to V⁻ will adversely affect reliability.

Note 5: The maximum power dissipation is a function of T_{J(MAX)}, θ_{JA}. The maximum allowable power dissipation at any ambient temperature is P_D = (T_{J(MAX)} - T_A) / θ_{JA}. All numbers apply for packages soldered directly onto a PC Board.

Note 6: Typical values represent the most likely parametric norm as determined at the time of characterization. Actual typical values may vary over time and will also depend on the application and configuration. The typical values are not tested and are not guaranteed on shipped production material.

Note 7: All limits are guaranteed by testing or statistical analysis.

Note 8: R_L is connected to V⁻. The output voltage is 0.5V ≤ V_O ≤ 4.5V.

Note 9: Connected as voltage follower with 3V step input. Number specified is the slower of the positive and negative slew rates.

Note 10: All numbers are typical, and apply for packages soldered directly onto a PC board in still air.

Connection Diagrams

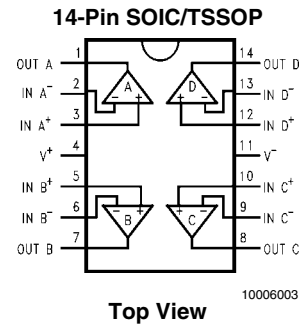
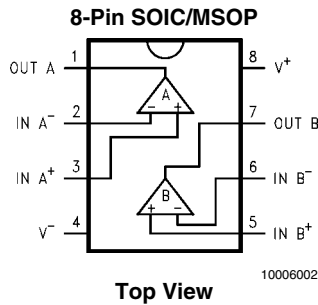
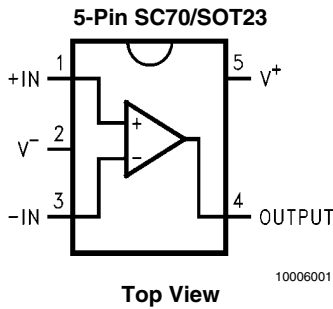

Ordering Information

Package	Temperature Range	Packaging Marking	Transport Media	NSC Drawing
	Industrial -40°C to +85°C			
5-Pin SC70	LMV321M7	A12	1k Units Tape and Reel	MAA05A
	LMV321M7X		3k Units Tape and Reel	
5-Pin SOT23	LMV321M5	A13	1k Units Tape and Reel	MF05A
	LMV321M5X		3k Units Tape and Reel	
8-Pin SOIC	LMV358M	LMV358M	Rails	M08A
	LMV358MX		2.5k Units Tape and Reel	
8-Pin MSOP	LMV358MM	LMV358	1k Units Tape and Reel	MUA08A
	LMV358MMX		3.5k Units Tape and Reel	
14-Pin SOIC	LMV324M	LMV324M	Rails	M14A
	LMV324MX		2.5k Units Tape and Reel	
14-Pin TSSOP	LMV324MT	LMV324MT	Rails	MTC14
	LMV324MTX		2.5k Units Tape and Reel	

Typical Performance Characteristics

Unless otherwise specified, $V_S = +5V$, single supply,

$T_A = 25^\circ C$.

Supply Current vs. Supply Voltage (LMV321)

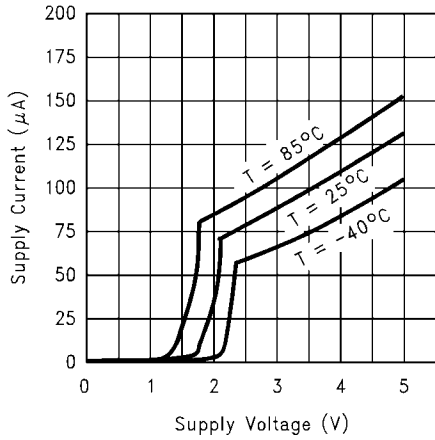

10006073

Input Current vs. Temperature

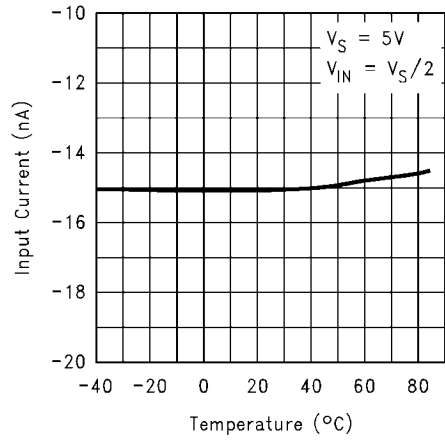

100060a9

Sourcing Current vs. Output Voltage

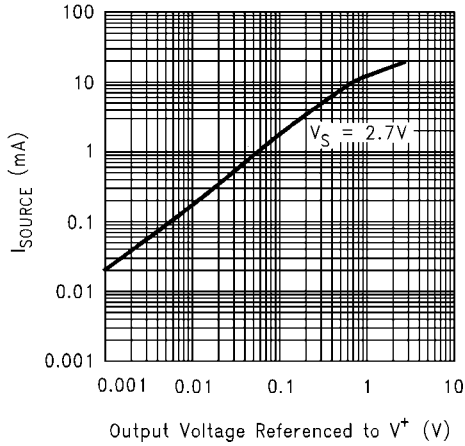

10006069

Sourcing Current vs. Output Voltage

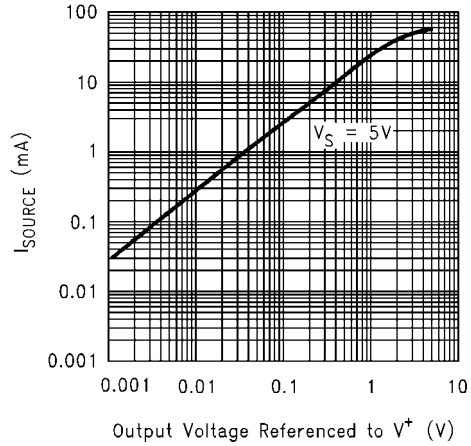

10006068

Sinking Current vs. Output Voltage

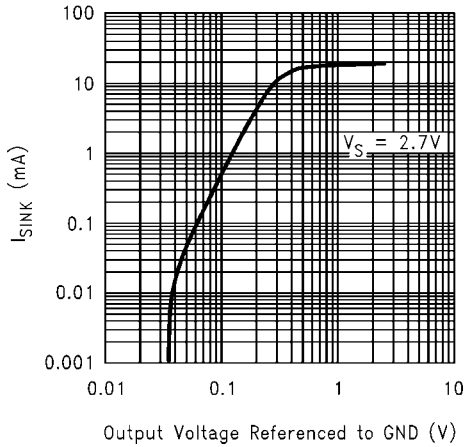

10006070

Sinking Current vs. Output Voltage

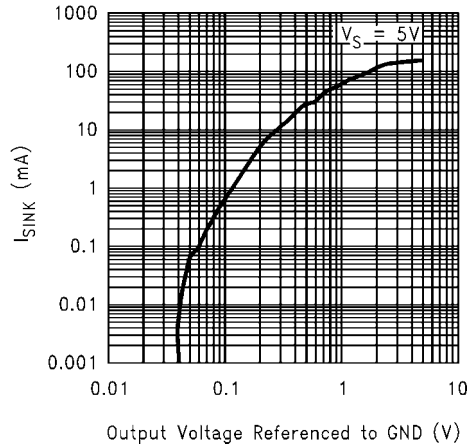

10006071

Output Voltage Swing vs. Supply Voltage

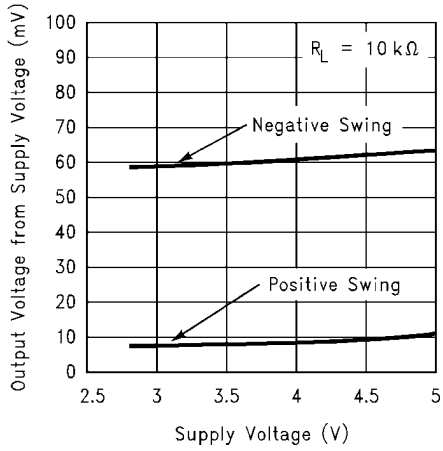

10006067

Input Voltage Noise vs. Frequency

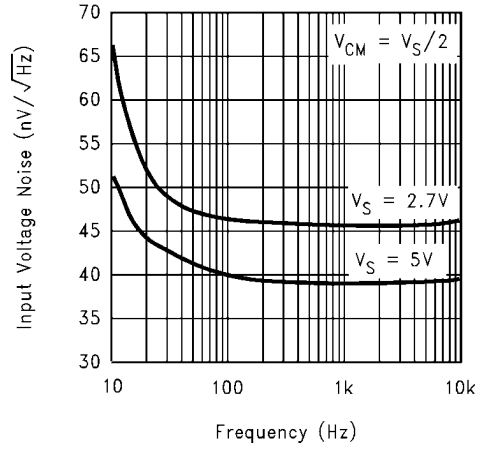

10006056

Input Current Noise vs. Frequency

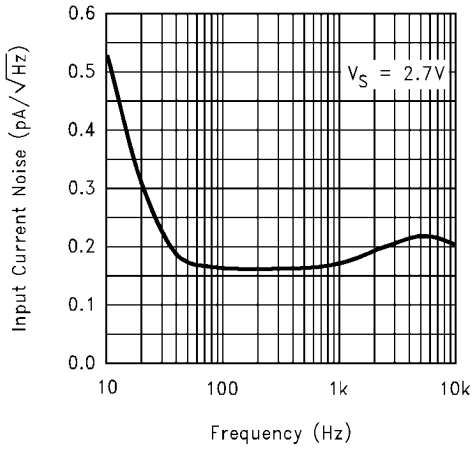

10006060

Input Current Noise vs. Frequency

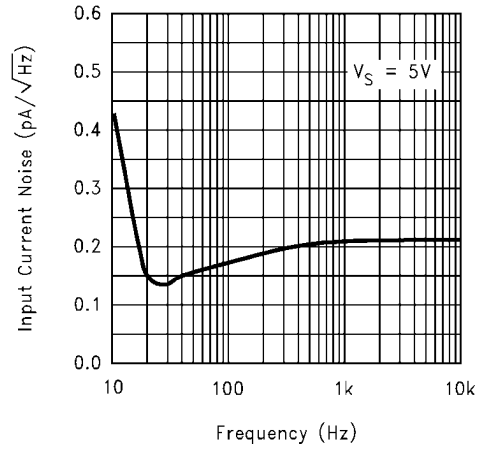

10006058

Crosstalk Rejection vs. Frequency

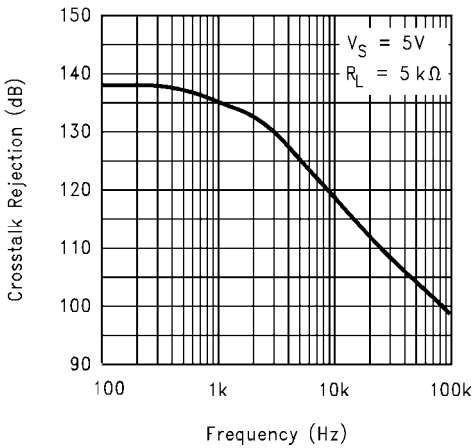

10006061

PSRR vs. Frequency

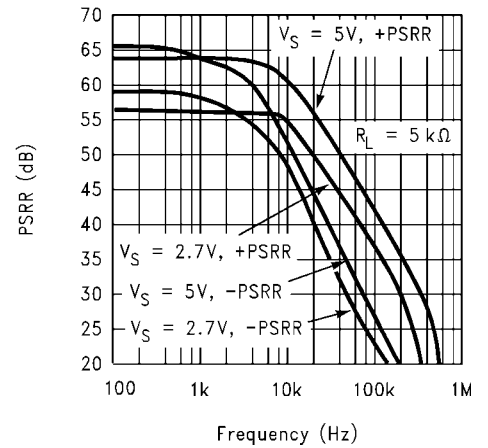

10006051

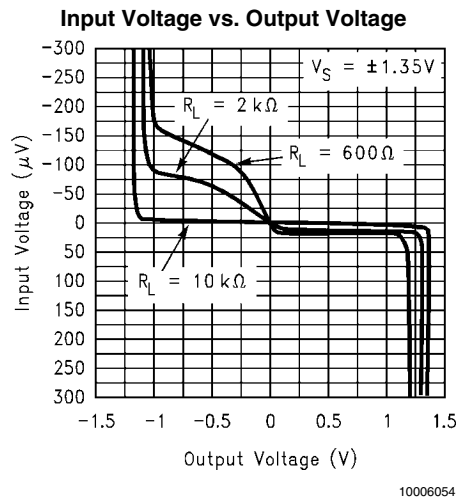
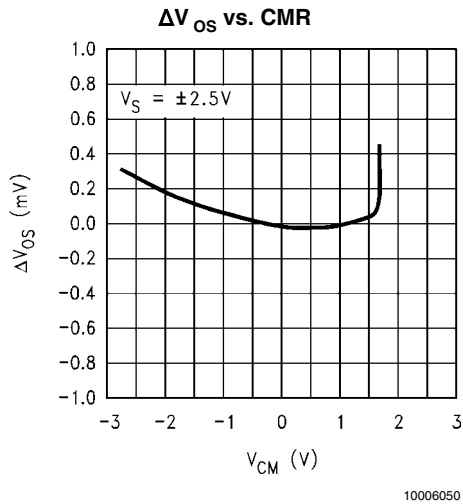
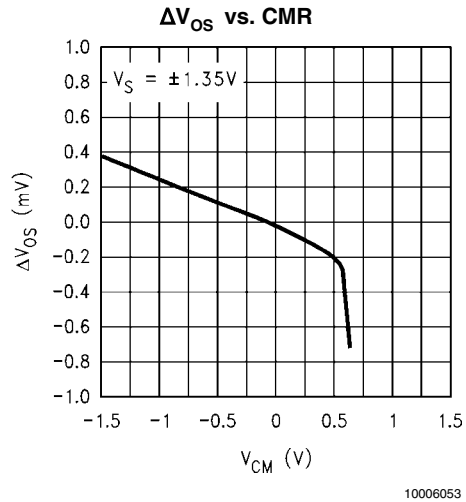
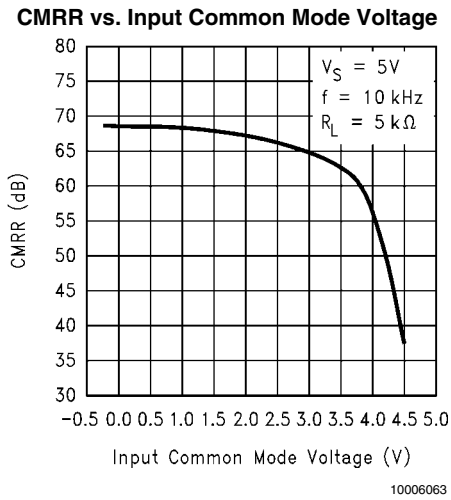
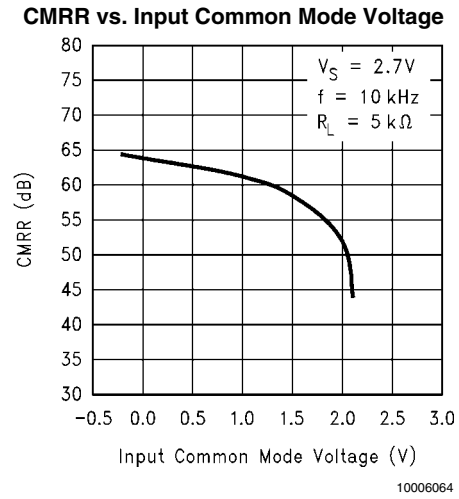
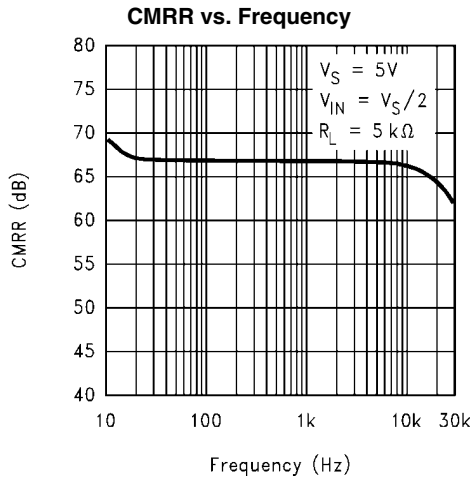

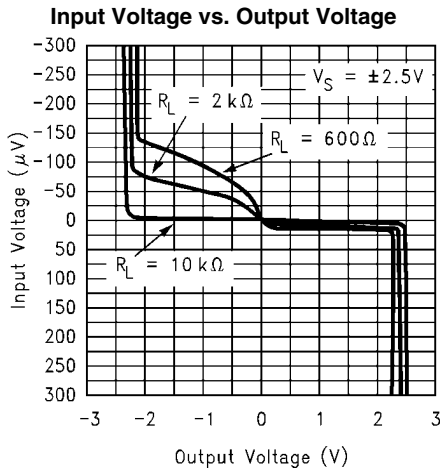

10006052

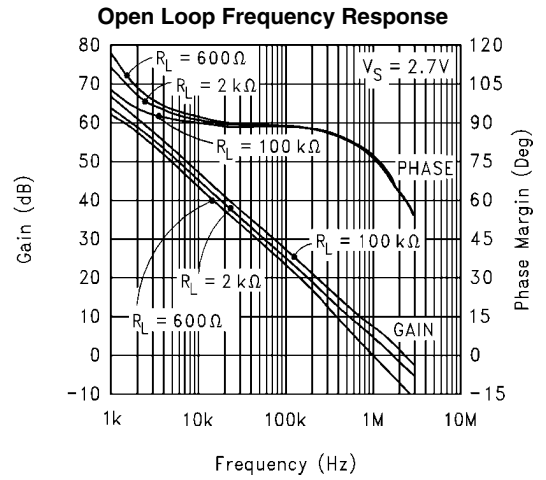

10006042

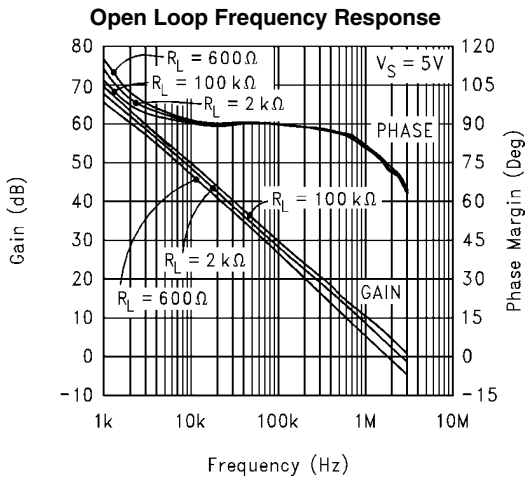

10006041

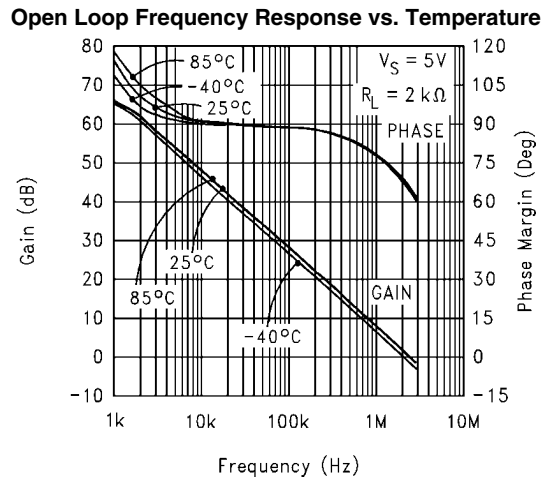

10006043

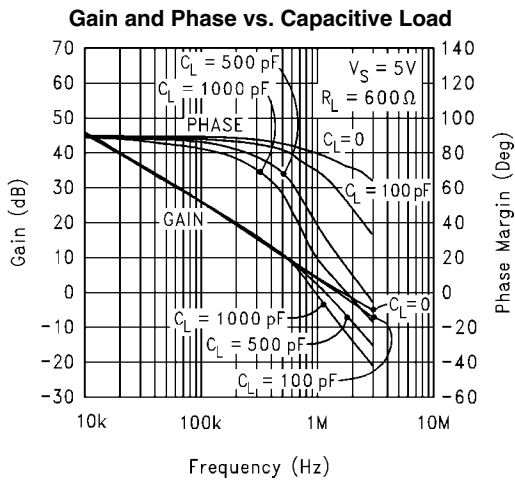

10006045

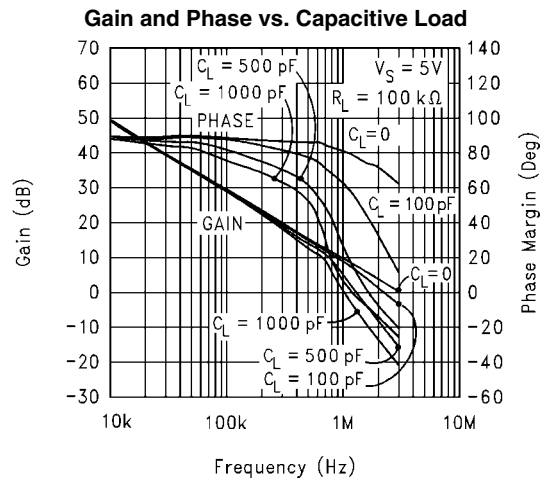

10006044

Slew Rate vs. Supply Voltage

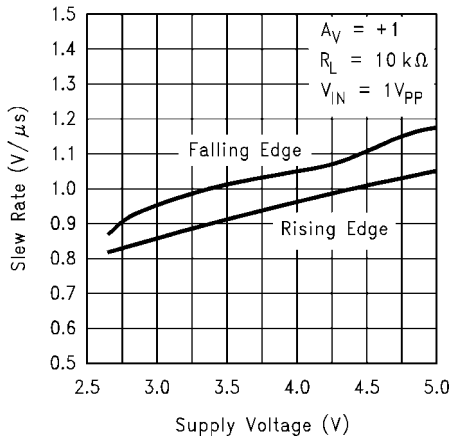

10006057

Non-Inverting Large Signal Pulse Response

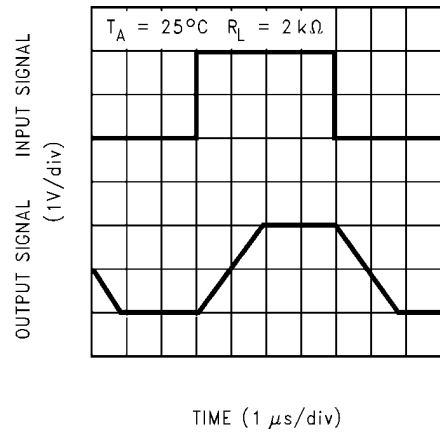

10006088

Non-Inverting Large Signal Pulse Response

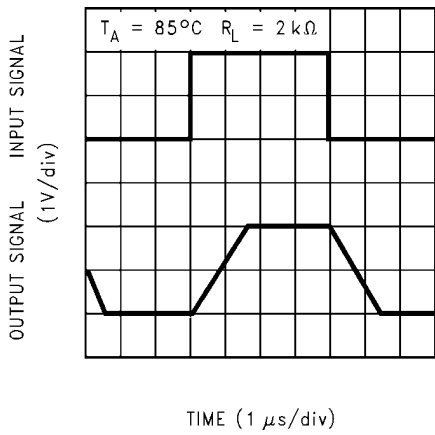

100060a1

Non-Inverting Large Signal Pulse Response

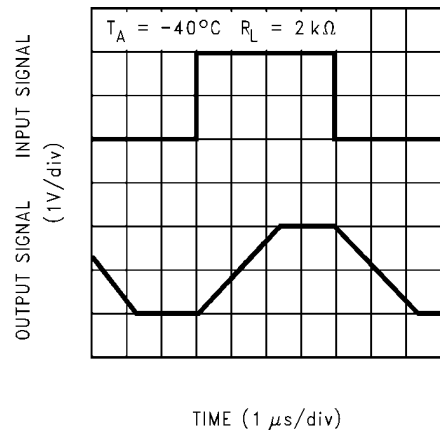

100060a0

Non-Inverting Small Signal Pulse Response

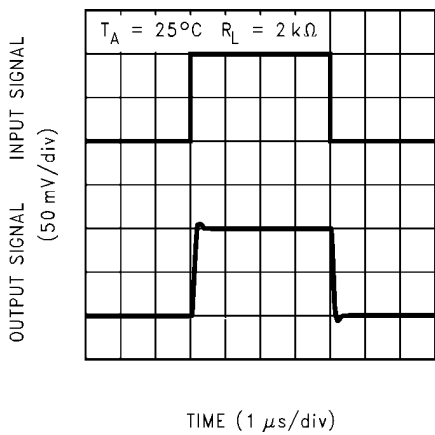

10006089

Non-Inverting Small Signal Pulse Response

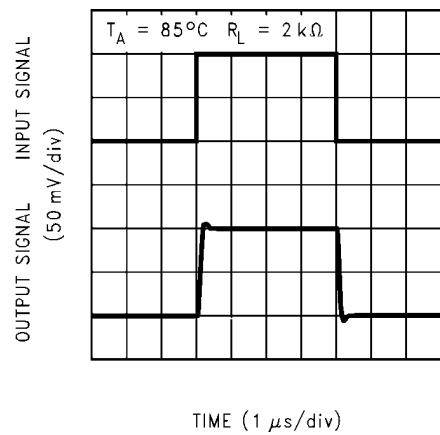

100060a2

Non-Inverting Small Signal Pulse Response

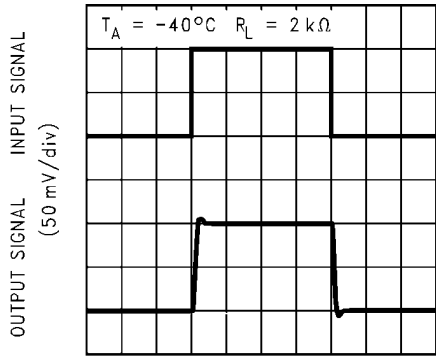

TIME (1 $\mu\text{s}/\text{div}$)

100060a3

Inverting Large Signal Pulse Response

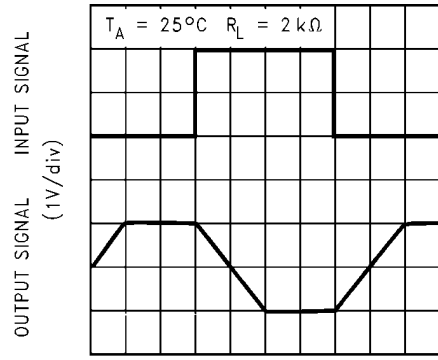

TIME (1 $\mu\text{s}/\text{div}$)

10006090

Inverting Large Signal Pulse Response

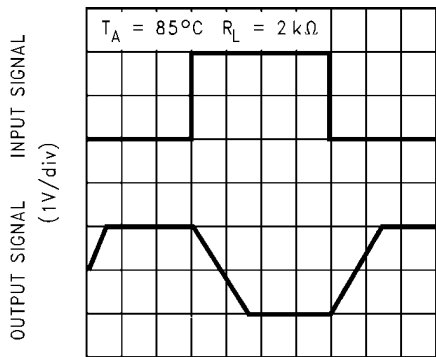

TIME (1 $\mu\text{s}/\text{div}$)

100060a4

Inverting Large Signal Pulse Response

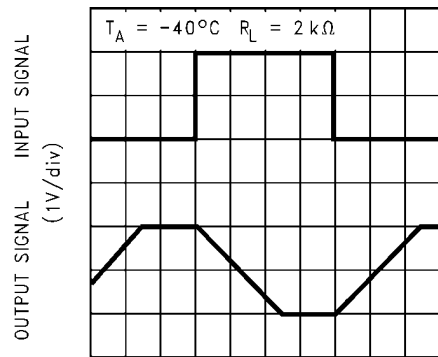

TIME (1 $\mu\text{s}/\text{div}$)

100060a5

Inverting Small Signal Pulse Response

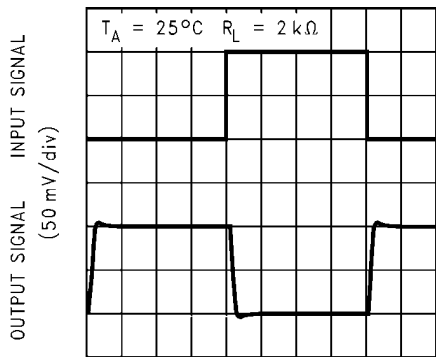

TIME (1 $\mu\text{s}/\text{div}$)

10006091

Inverting Small Signal Pulse Response

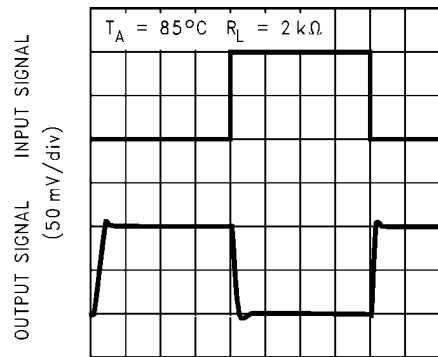

TIME (1 $\mu\text{s}/\text{div}$)

100060a6

Inverting Small Signal Pulse Response

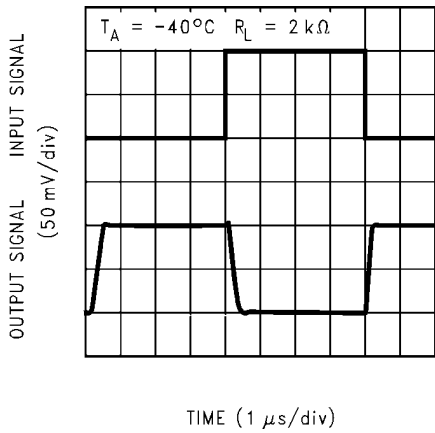

100060a7

Stability vs. Capacitive Load

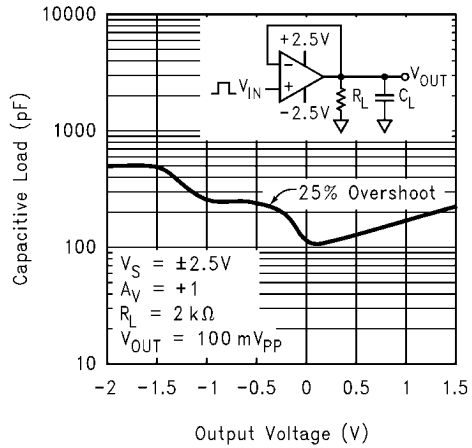

10006046

Stability vs. Capacitive Load

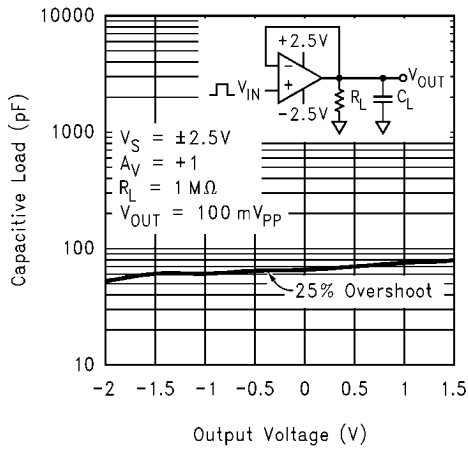

10006047

Stability vs. Capacitive Load

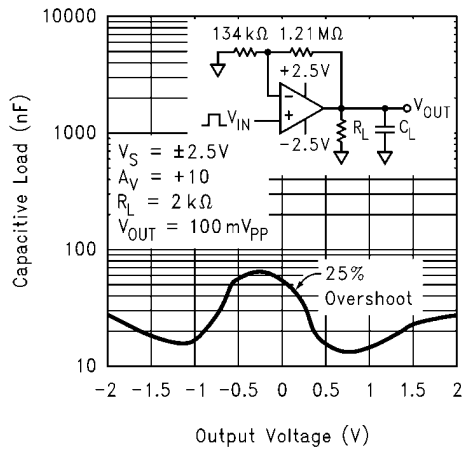

10006049

Stability vs. Capacitive Load

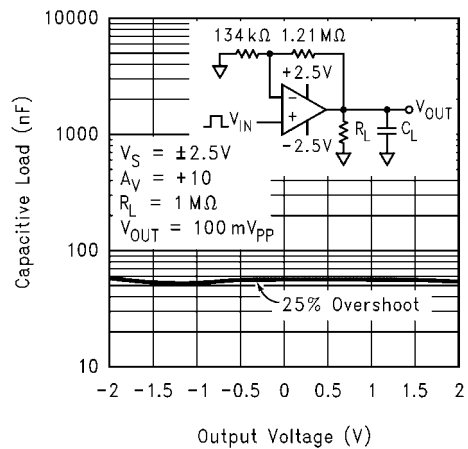

10006048

THD vs. Frequency

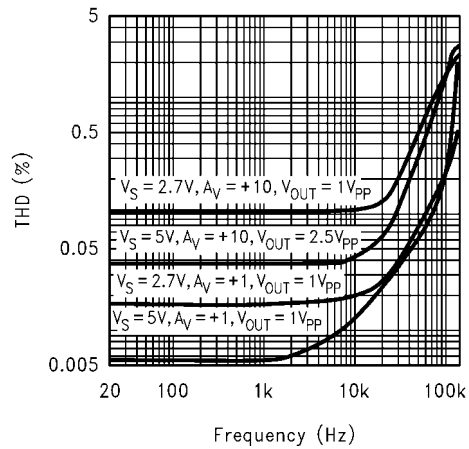

10006059

Open Loop Output Impedance vs. Frequency

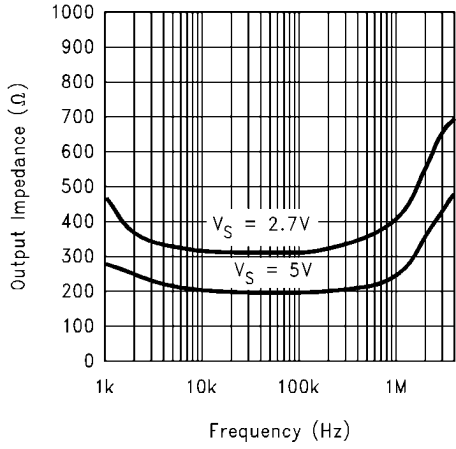

10006055

Short Circuit Current vs. Temperature (Sinking)

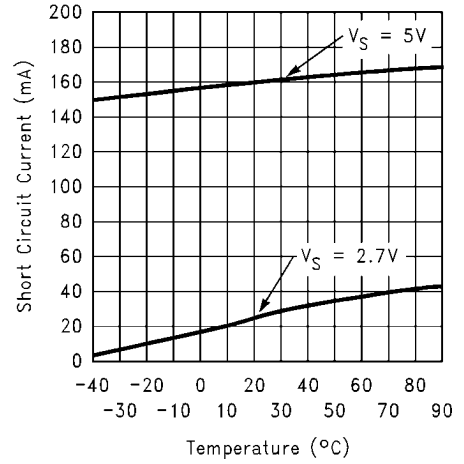

10006065

Short Circuit Current vs. Temperature (Sourcing)

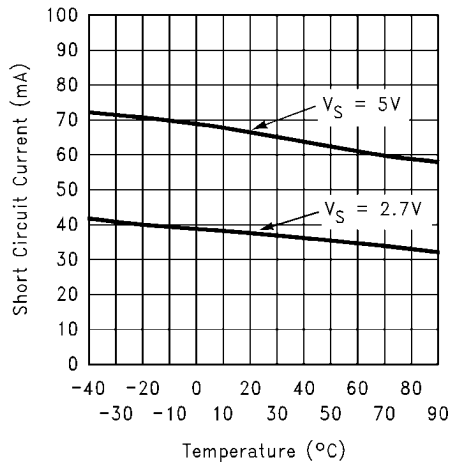

10006066

Application Information

BENEFITS OF THE LMV321/LMV358/LMV324

Size

The small footprints of the LMV321/LMV358/LMV324 packages save space on printed circuit boards, and enable the design of smaller electronic products, such as cellular phones, pagers, or other portable systems. The low profile of the LMV321/LMV358/LMV324 make them possible to use in PCMCIA type III cards.

Signal Integrity

Signals can pick up noise between the signal source and the amplifier. By using a physically smaller amplifier package, the LMV321/LMV358/LMV324 can be placed closer to the signal source, reducing noise pickup and increasing signal integrity.

Simplified Board Layout

These products help you to avoid using long PC traces in your PC board layout. This means that no additional components, such as capacitors and resistors, are needed to filter out the unwanted signals due to the interference between the long PC traces.

Low Supply Current

These devices will help you to maximize battery life. They are ideal for battery powered systems.

Low Supply Voltage

National provides guaranteed performance at 2.7V and 5V. These guarantees ensure operation throughout the battery lifetime.

Rail-to-Rail Output

Rail-to-rail output swing provides maximum possible dynamic range at the output. This is particularly important when operating on low supply voltages.

Input Includes Ground

Allows direct sensing near GND in single supply operation. The differential input voltage may be larger than V^+ without damaging the device. Protection should be provided to prevent the input voltages from going negative more than $-0.3V$ (at $25^\circ C$). An input clamp diode with a resistor to the IC input terminal can be used.

Ease of Use and Crossover Distortion

The LMV321/LMV358/LMV324 offer specifications similar to the familiar LM324. In addition, the new LMV321/LMV358/LMV324 effectively eliminate the output crossover distortion. The scope photos in *Figure 1* and *Figure 2* compare the output swing of the LMV324 and the LM324 in a voltage follower configuration, with $V_S = \pm 2.5V$ and $R_L (= 2\text{ k}\Omega)$ connected to GND. It is apparent that the crossover distortion has been eliminated in the new LMV324.

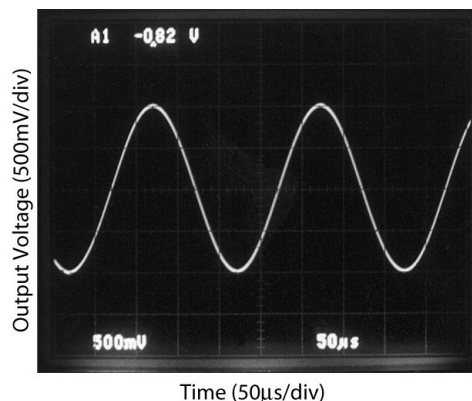

FIGURE 1. Output Swing of LMV324

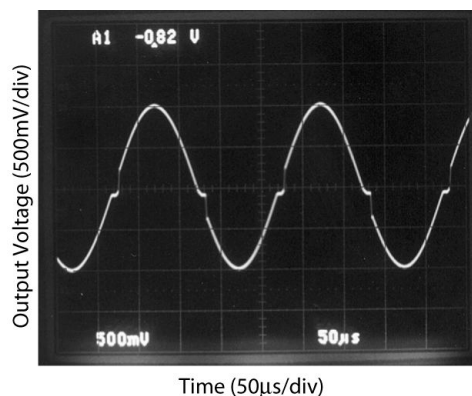

FIGURE 2. Output Swing of LM324

CAPACITIVE LOAD TOLERANCE

The LMV321/LMV358/LMV324 can directly drive 200 pF in unity-gain without oscillation. The unity-gain follower is the most sensitive configuration to capacitive loading. Direct capacitive loading reduces the phase margin of amplifiers. The combination of the amplifier's output impedance and the capacitive load induces phase lag. This results in either an underdamped pulse response or oscillation. To drive a heavier capacitive load, the circuit in *Figure 3* can be used.

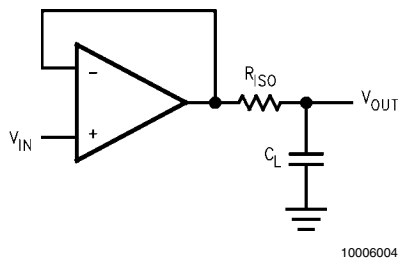

FIGURE 3. Indirectly Driving a Capacitive Load Using Resistive Isolation

In *Figure 3*, the isolation resistor R_{ISO} and the load capacitor C_L form a pole to increase stability by adding more phase margin to the overall system. The desired performance depends on the value of R_{ISO} . The bigger the R_{ISO} resistor value, the more stable V_{OUT} will be. *Figure 4* is an output waveform of *Figure 3* using 620Ω for R_{ISO} and 510 pF for C_L .

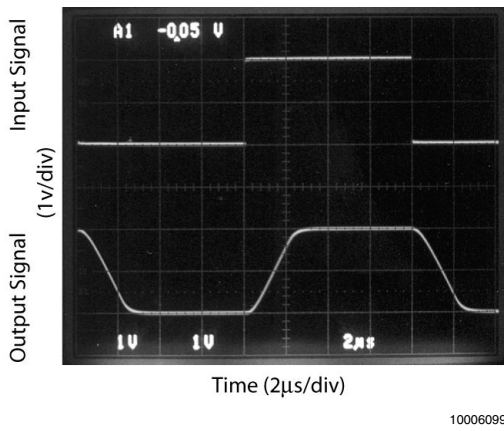

FIGURE 4. Pulse Response of the LMV324 Circuit in *Figure 3*

The circuit in *Figure 5* is an improvement to the one in *Figure 3* because it provides DC accuracy as well as AC stability. If there were a load resistor in *Figure 3*, the output would be voltage divided by R_{ISO} and the load resistor. Instead, in *Figure 5*, R_F provides the DC accuracy by using feed-forward techniques to connect V_{IN} to R_L . Caution is needed in choosing the value of R_F due to the input bias current of the LMV321/LMV358/LMV324. C_F and R_{ISO} serve to counteract the loss of phase margin by feeding the high frequency component of the output signal back to the amplifier's inverting input, thereby preserving phase margin in the overall feedback loop. Increased capacitive drive is possible by increasing the value of C_F . This in turn will slow down the pulse response.

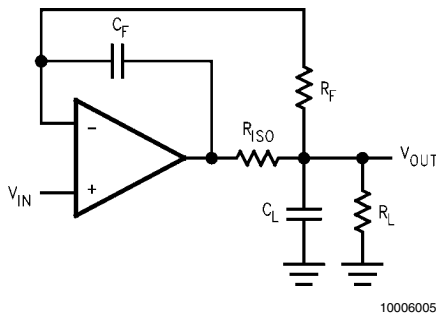
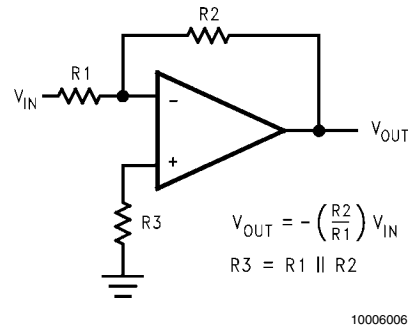

FIGURE 5. Indirectly Driving A Capacitive Load with DC Accuracy

INPUT BIAS CURRENT CANCELLATION

The LMV321/LMV358/LMV324 family has a bipolar input stage. The typical input bias current of LMV321/LMV358/LMV324 is 15 nA with 5V supply. Thus a 100 kΩ input resistor will cause 1.5 mV of error voltage. By balancing the resistor values at both inverting and non-inverting inputs, the error caused by the amplifier's input bias current will be reduced. The circuit in *Figure 6* shows how to cancel the error caused by input bias current.



$$V_{OUT} = -\left(\frac{R_2}{R_1}\right) V_{IN}$$

$$R_3 = R_1 \parallel R_2$$

FIGURE 6. Cancelling the Error Caused by Input Bias Current

TYPICAL SINGLE-SUPPLY APPLICATION CIRCUITS

Difference Amplifier

The difference amplifier allows the subtraction of two voltages or, as a special case, the cancellation of a signal common to two inputs. It is useful as a computational amplifier, in making a differential to single-ended conversion or in rejecting a common mode signal.

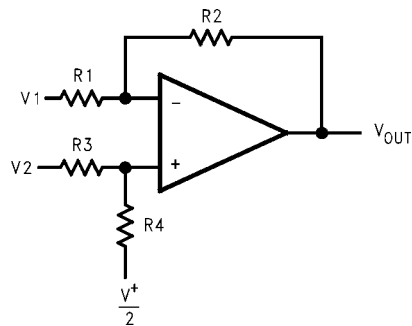

$$V_{OUT} = \left(\frac{R_1 + R_2}{R_3 + R_4}\right) \frac{R_4}{R_1} V_2 - \frac{R_2}{R_1} V_1 + \left(\frac{R_1 + R_2}{R_3 + R_4}\right) \frac{R_3}{R_1} \cdot \frac{V^+}{2}$$

for $R_1 = R_3$ and $R_2 = R_4$

$$V_{OUT} = \frac{R_2}{R_1} (V_2 - V_1) + \frac{V^+}{2}$$

FIGURE 7. Difference Amplifier

Instrumentation Circuits

The input impedance of the previous difference amplifier is set by the resistors R_1 , R_2 , R_3 , and R_4 . To eliminate the problems of low input impedance, one way is to use a voltage follower ahead of each input as shown in the following two instrumentation amplifiers.

Three-Op-Amp Instrumentation Amplifier

The quad LMV324 can be used to build a three-op-amp instrumentation amplifier as shown in *Figure 8*.

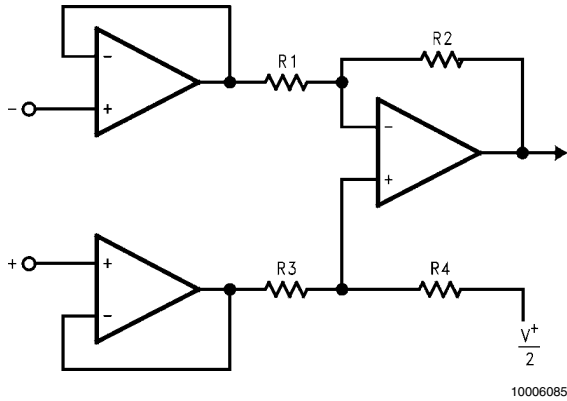

10006085

FIGURE 8. Three-Op-Amp Instrumentation Amplifier

The first stage of this instrumentation amplifier is a differential-input, differential-output amplifier, with two voltage followers. These two voltage followers assure that the input impedance is over 100 MΩ. The gain of this instrumentation amplifier is set by the ratio of R_2/R_1 . R_3 should equal R_1 , and R_4 equal R_2 . Matching of R_3 to R_1 and R_4 to R_2 affects the CMRR. For good CMRR over temperature, low drift resistors should be used. Making R_4 slightly smaller than R_2 and adding a trim pot equal to twice the difference between R_2 and R_4 will allow the CMRR to be adjusted for optimum performance.

Two-Op-Amp Instrumentation Amplifier

A two-op-amp instrumentation amplifier can also be used to make a high-input-impedance DC differential amplifier (*Figure 9*). As in the three-op-amp circuit, this instrumentation amplifier requires precise resistor matching for good CMRR. R_4 should equal R_1 and, R_3 should equal R_2 .

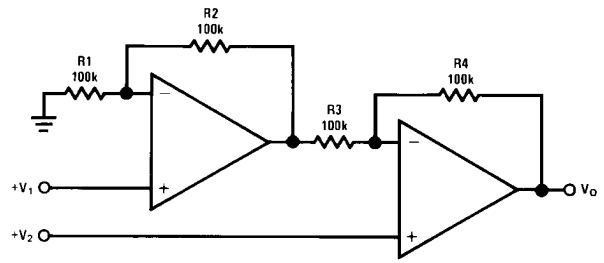

10006011

$$V_O = \left(1 + \frac{R_4}{R_3}\right)(V_2 - V_1), \text{ where } R_1 = R_4 \text{ and } R_2 = R_3$$

$$\text{As shown: } V_O = 2(V_2 - V_1)$$

10006035

FIGURE 9. Two-Op-Amp Instrumentation Amplifier

Single-Supply Inverting Amplifier

There may be cases where the input signal going into the amplifier is negative. Because the amplifier is operating in single supply voltage, a voltage divider using R_3 and R_4 is implemented to bias the amplifier so the input signal is within the input common-mode voltage range of the amplifier. The capacitor C_1 is placed between the inverting input and resistor R_1 to block the DC signal going into the AC signal source, V_{IN} . The values of R_1 and C_1 affect the cutoff frequency, $f_c = 1/2\pi R_1 C_1$.

As a result, the output signal is centered around mid-supply (if the voltage divider provides $V^+/2$ at the non-inverting input). The output can swing to both rails, maximizing the signal-to-noise ratio in a low voltage system.

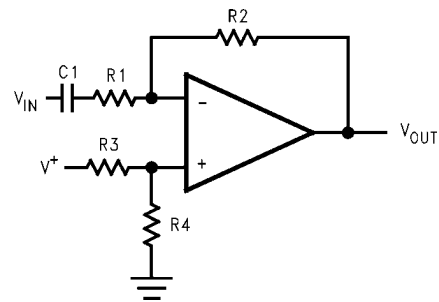

10006013

$$V_{OUT} = -\frac{R_2}{R_1} V_{IN}$$

10006020

FIGURE 10. Single-Supply Inverting Amplifier

ACTIVE FILTER

Simple Low-Pass Active Filter

The simple low-pass filter is shown in *Figure 11*. Its low-frequency gain ($\omega \rightarrow 0$) is defined by $-R_3/R_1$. This allows low-frequency gains other than unity to be obtained. The filter has a -20 dB/decade roll-off after its corner frequency f_c . R_2 should be chosen equal to the parallel combination of R_1 and R_3 to minimize errors due to bias current. The frequency response of the filter is shown in *Figure 12*.

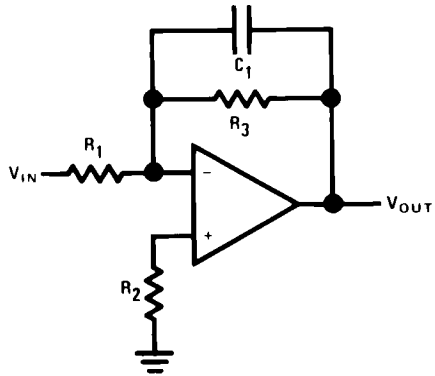

$$A_L = -\frac{R_3}{R_1}$$

$$f_c = \frac{1}{2\pi R_3 C_1}$$

$$R_2 = R_1 \parallel R_3$$

10006014
10006037

FIGURE 11. Simple Low-Pass Active Filter

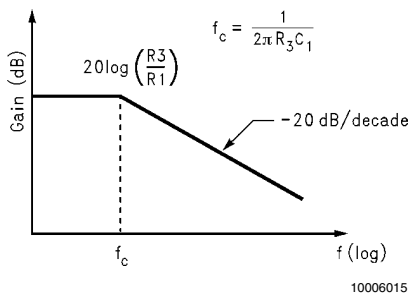

FIGURE 12. Frequency Response of Simple Low-Pass Active Filter in Figure 11

Note that the single-op-amp active filters are used in the applications that require low quality factor, $Q (\leq 10)$, low frequency (≤ 5 kHz), and low gain (≤ 10), or a small value for the product of gain times $Q (\leq 100)$. The op amp should have an open loop voltage gain at the highest frequency of interest at least 50 times larger than the gain of the filter at this frequency. In addition, the selected op amp should have a slew rate that meets the following requirement:

$$\text{Slew Rate} \geq 0.5 \times (\omega_H V_{OPP}) \times 10^{-6} \text{ V}/\mu\text{sec}$$

where ω_H is the highest frequency of interest, and V_{OPP} is the output peak-to-peak voltage.

Sallen-Key 2nd-Order Active Low-Pass Filter

The Sallen-Key 2nd-order active low-pass filter is illustrated in *Figure 13*. The DC gain of the filter is expressed as

$$A_{LP} = \frac{R_3}{R_4} + 1 \tag{1}$$

Its transfer function is

$$\frac{V_{OUT}}{V_{IN}}(S) = \frac{\frac{1}{C_1 C_2 R_1 R_2} A_{LP}}{S^2 + S \left(\frac{1}{C_1 R_1} + \frac{1}{C_1 R_2} + \frac{1}{C_2 R_2} - \frac{A_{LP}}{C_2 R_2} \right) + \frac{1}{C_1 C_2 R_1 R_2}} \tag{2}$$

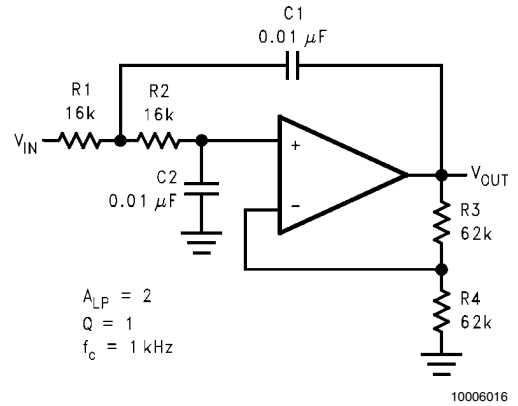

$$A_{LP} = 2$$

$$Q = 1$$

$$f_c = 1 \text{ kHz}$$

10006016

FIGURE 13. Sallen-Key 2nd-Order Active Low-Pass Filter

The following paragraphs explain how to select values for R_1 , R_2 , R_3 , R_4 , C_1 , and C_2 for given filter requirements, such as A_{LP} , Q , and f_c .

The standard form for a 2nd-order low pass filter is

$$\frac{V_{OUT}}{V_{IN}}(S) = \frac{A_{LP} \omega_c^2}{S^2 + \left(\frac{\omega_c}{Q} \right) S + \omega_c^2} \tag{3}$$

where

Q : Pole Quality Factor

ω_c : Corner Frequency

A comparison between *Equation 2* and *Equation 3* yields

$$\omega_c^2 = \frac{1}{C_1 C_2 R_1 R_2} \tag{4}$$

$$\frac{\omega_c}{Q} = \frac{1}{C_1 R_1} + \frac{1}{C_1 R_2} + \frac{1}{C_2 R_2} - \frac{A_{LP}}{C_2 R_2} \tag{5}$$

To reduce the required calculations in filter design, it is convenient to introduce normalization into the components and design parameters. To normalize, let $\omega_c = \omega_n = 1$ rad/s, and $C_1 = C_2 = C_n = 1$ F, and substitute these values into *Equation 4* and *Equation 5*. From *Equation 4*, we obtain

$$R_1 = \frac{1}{R_2} \tag{6}$$

From *Equation 5*, we obtain

$$R_2 = \frac{1 \pm \sqrt{1 - 4Q^2(2 - A_{LP})}}{2Q} \tag{7}$$

For minimum DC offset, $V^+ = V^-$, the resistor values at both inverting and non-inverting inputs should be equal, which means

$$R_1 + R_2 = \frac{R_3 R_4}{R_3 + R_4} \quad (8)$$

From Equation 1 and Equation 8, we obtain

$$R_3 = (R_1 + R_2) A_{LP} \quad (9)$$

$$R_4 = \left(\frac{A_{LP}}{A_{LP} - 1} \right) (R_1 + R_2) \quad (10)$$

The values of C_1 and C_2 are normally close to or equal to

$$C = \frac{10}{f_c} \mu F$$

As a design example:

Require: $A_{LP} = 2$, $Q = 1$, $f_c = 1$ kHz

Start by selecting C_1 and C_2 . Choose a standard value that is close to

$$C = \frac{10}{f_c} \mu F$$

$$C_1 = C_2 = \frac{10}{1 \times 10^3} \mu F = 0.01 \mu F$$

From Equations 6, 7, 9, 10,

$$R_1 = 1\Omega$$

$$R_2 = 1\Omega$$

$$R_3 = 4\Omega$$

$$R_4 = 4\Omega$$

The above resistor values are normalized values with $\omega_n = 1$ rad/s and $C_1 = C_2 = C_n = 1F$. To scale the normalized cutoff frequency and resistances to the real values, two scaling factors are introduced, frequency scaling factor (k_f) and impedance scaling factor (k_m).

$$k_f = \frac{\omega_c}{\omega_n} = \frac{2\pi \times 1 \times 10^3}{1} = 2\pi \times 10^3$$

$$k_m k_f = \frac{C_n}{C_1}$$

$$k_m = 1.59 \times 10^4$$

Scaled values:

$$R_2 = R_1 = 15.9 \text{ k}\Omega$$

$$R_3 = R_4 = 63.6 \text{ k}\Omega$$

$$C_1 = C_2 = 0.01 \mu F$$

An adjustment to the scaling may be made in order to have realistic values for resistors and capacitors. The actual value used for each component is shown in the circuit.

2nd-Order High Pass Filter

A 2nd-order high pass filter can be built by simply interchanging those frequency selective components (R_1, R_2, C_1, C_2) in the Sallen-Key 2nd-order active low pass filter. As shown in Figure 14, resistors become capacitors, and capacitors become resistors. The resulted high pass filter has the same corner frequency and the same maximum gain as the previous 2nd-order low pass filter if the same components are chosen.

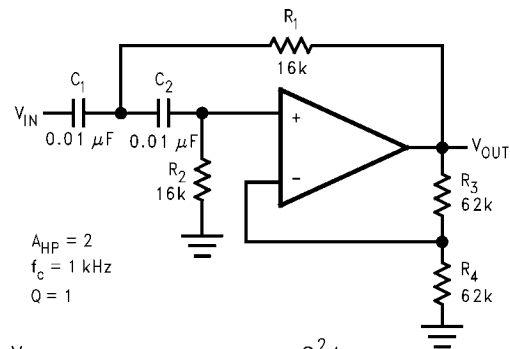

$A_{HP} = 2$
 $f_c = 1$ kHz
 $Q = 1$

$$\frac{V_{OUT}}{V_{IN}}(s) = \frac{s^2 A_{HP}}{s^2 + s \left(\frac{1}{C_1 R_2} + \frac{1}{C_2 R_2} + \frac{(1 - A_{HP})}{C_1 R_1} \right) + \frac{1}{C_1 C_2 R_1 R_2}}$$

Where $A_{HP} = 1 + \frac{R_3}{R_4}$

10006083

FIGURE 14. Sallen-Key 2nd-Order Active High-Pass Filter

State Variable Filter

A state variable filter requires three op amps. One convenient way to build state variable filters is with a quad op amp, such as the LMV324 (Figure 15).

This circuit can simultaneously represent a low-pass filter, high-pass filter, and bandpass filter at three different outputs. The equations for these functions are listed below. It is also called "Bi-Quad" active filter as it can produce a transfer function which is quadratic in both numerator and denominator.

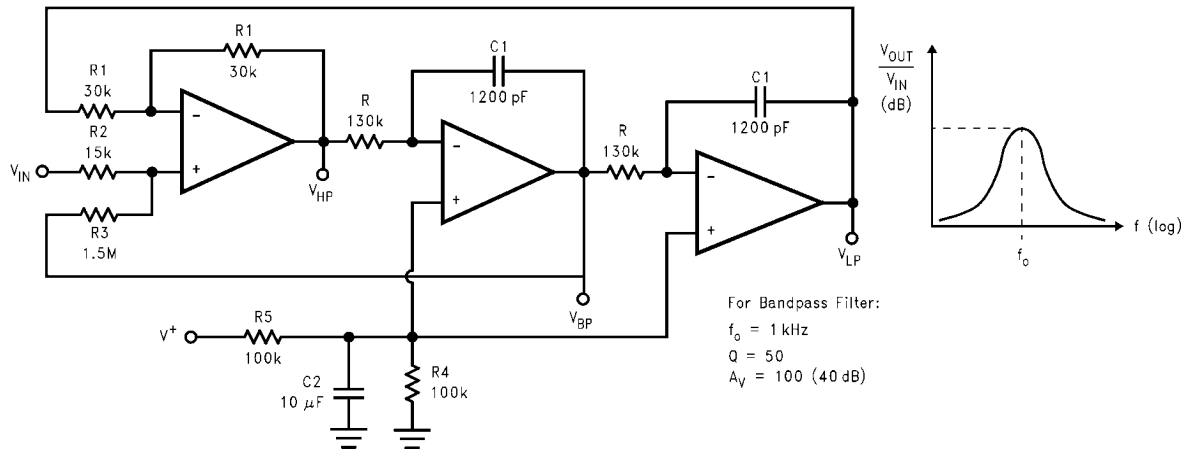

10006039

FIGURE 15. State Variable Active Filter

$$V_{LP} = \left(\frac{2R_3}{R_2 + R_3} \right) \frac{\frac{1}{R^2 C^2}}{S^2 + \frac{1}{\left(\frac{R_2 + R_3}{2R_2} \right) RC} S + \frac{1}{R^2 C^2}} V_{IN}$$

$$V_{HP} = \left(\frac{2R_3}{R_2 + R_3} \right) \frac{S^2}{S^2 + \frac{1}{\left(\frac{R_2 + R_3}{2R_2} \right) RC} S + \frac{1}{R^2 C^2}} V_{IN}$$

$$V_{BP} = \left(\frac{2R_3}{R_2 + R_3} \right) \frac{\left(\frac{1}{RC} \right) S}{S^2 + \frac{1}{\left(\frac{R_2 + R_3}{2R_2} \right) RC} S + \frac{1}{R^2 C^2}} V_{IN}$$

From Equation 12,

$$R = \frac{1}{\omega_0 C_1}$$

$$R = \frac{1}{(2\pi \times 10^3)(1.2 \times 10^{-9})}$$

$$= 132.7 \text{ k}\Omega$$

From the above calculated values, the midband gain is $H_0 = R_3/R_2 = 100$ (40 dB). The nearest 5% standard values have been added to Figure 15.

PULSE GENERATORS AND OSCILLATORS

A pulse generator is shown in Figure 16. Two diodes have been used to separate the charge and discharge paths to capacitor C.

where for all three filters,

$$Q = \frac{R_2 + R_3}{2R_2} \tag{11}$$

$$\omega_0 = \frac{1}{RC} \text{ (resonant frequency)} \tag{12}$$

A design example for a bandpass filter is shown below:

Assume the system design requires a bandpass filter with $f_0 = 1 \text{ kHz}$ and $Q = 50$. What needs to be calculated are capacitor and resistor values.

First choose convenient values for C_1 , R_1 and R_2 :

$$C_1 = 1200 \text{ pF}$$

$$2R_2 = R_1 = 30 \text{ k}\Omega$$

Then from Equation 11,

$$R_3 = R_2(2Q - 1)$$

$$R_3 = 15 \text{ k}\Omega \times (2 \times 50 - 1)$$

$$= 1.5 \text{ M}\Omega$$

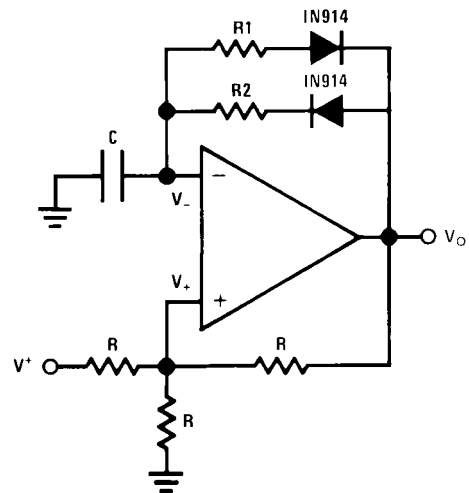

10006081

FIGURE 16. Pulse Generator

When the output voltage V_O is first at its high, V_{OH} , the capacitor C is charged toward V_{OH} through R_2 . The voltage across C rises exponentially with a time constant $\tau = R_2C$, and this voltage is applied to the inverting input of the op amp. Meanwhile, the voltage at the non-inverting input is set at the positive threshold voltage (V_{TH+}) of the generator. The capacitor voltage continually increases until it reaches V_{TH+} , at which point the output of the generator will switch to its low, V_{OL} which 0V is in this case. The voltage at the non-inverting input is switched to the negative threshold voltage (V_{TH-}) of the generator. The capacitor then starts to discharge toward V_{OL} exponentially through R_1 , with a time constant $\tau = R_1C$. When the capacitor voltage reaches V_{TH-} , the output of the pulse generator switches to V_{OH} . The capacitor starts to charge, and the cycle repeats itself.

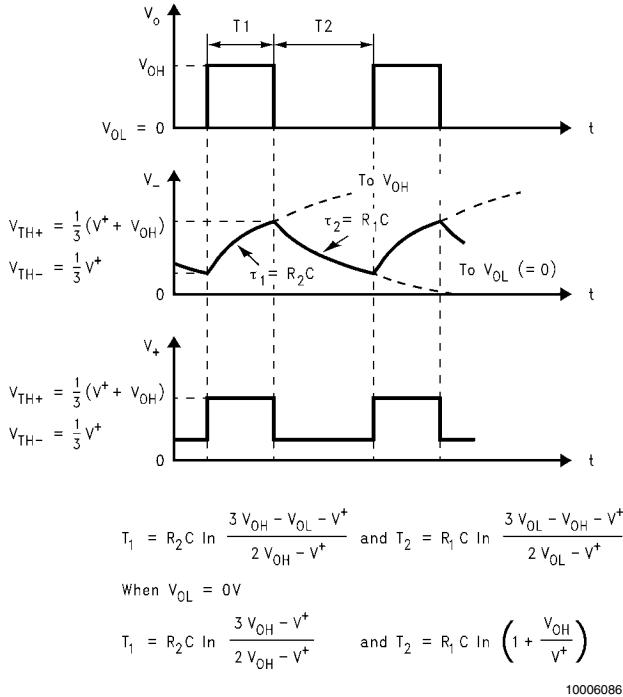
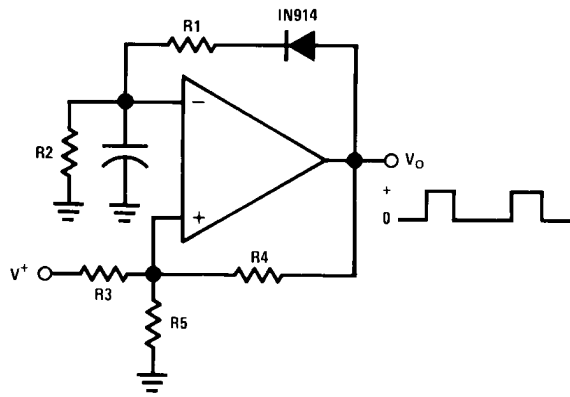

FIGURE 17. Waveforms of the Circuit in Figure 16

As shown in the waveforms in *Figure 17*, the pulse width (T_1) is set by R_2 , C and V_{OH} , and the time between pulses (T_2) is set by R_1 , C and V_{OL} . This pulse generator can be made to have different frequencies and pulse width by selecting different capacitor value and resistor values.

Figure 18 shows another pulse generator, with separate charge and discharge paths. The capacitor is charged through R_1 and is discharged through R_2 .



10006077

FIGURE 18. Pulse Generator

Figure 19 is a squarewave generator with the same path for charging and discharging the capacitor.

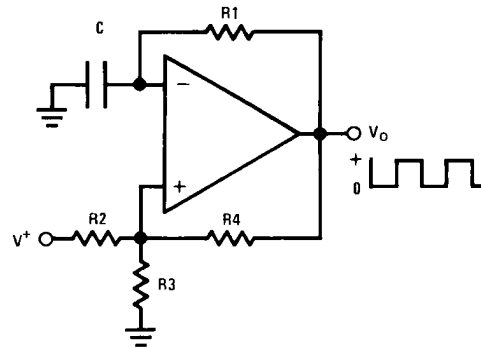

10006076

FIGURE 19. Squarewave Generator

CURRENT SOURCE AND SINK

The LMV321/LMV358/LMV324 can be used in feedback loops which regulate the current in external PNP transistors to provide current sources or in external NPN transistors to provide current sinks.

Fixed Current Source

A multiple fixed current source is shown in *Figure 20*. A voltage ($V_{REF} = 2V$) is established across resistor R_3 by the voltage divider (R_3 and R_4). Negative feedback is used to cause the voltage drop across R_1 to be equal to V_{REF} . This controls the emitter current of transistor Q_1 and if we neglect the base current of Q_1 and Q_2 , essentially this same current is available out of the collector of Q_1 .

Large input resistors can be used to reduce current loss and a Darlington connection can be used to reduce errors due to the β of Q_1 .

The resistor, R_2 , can be used to scale the collector current of Q_2 either above or below the 1 mA reference value.

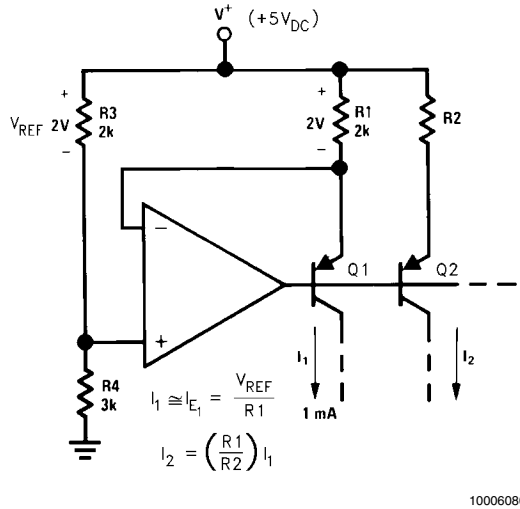

FIGURE 20. Fixed Current Source

High Compliance Current Sink

A current sink circuit is shown in Figure 21. The circuit requires only one resistor (R_E) and supplies an output current which is directly proportional to this resistor value.

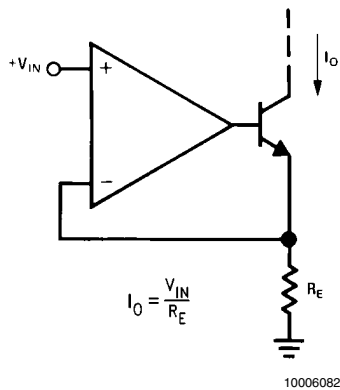

FIGURE 21. High Compliance Current Sink

POWER AMPLIFIER

A power amplifier is illustrated in Figure 22. This circuit can provide a higher output current because a transistor follower is added to the output of the op amp.

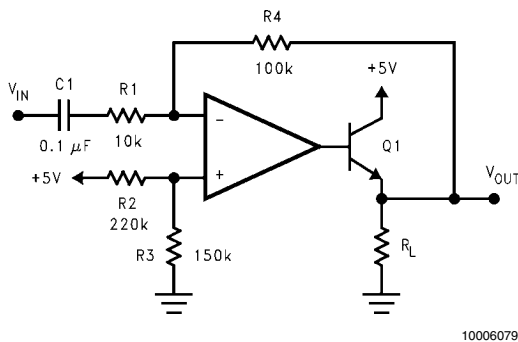

FIGURE 22. Power Amplifier

LED DRIVER

The LMV321/LMV358/LMV324 can be used to drive an LED as shown in Figure 23.

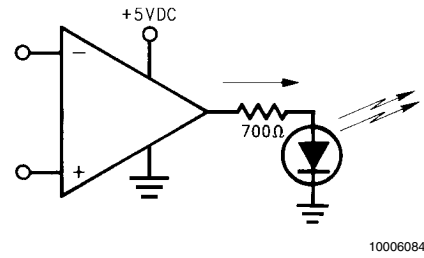

FIGURE 23. LED Driver

COMPARATOR WITH HYSTERESIS

The LMV321/LMV358/LMV324 can be used as a low power comparator. Figure 24 shows a comparator with hysteresis. The hysteresis is determined by the ratio of the two resistors.

$$V_{TH+} = V_{REF}/(1+R_1/R_2) + V_{OH}/(1+R_2/R_1)$$

$$V_{TH-} = V_{REF}/(1+R_1/R_2) + V_{OL}/(1+R_2/R_1)$$

$$V_H = (V_{OH} - V_{OL})/(1+R_2/R_1)$$

where

- V_{TH+} : Positive Threshold Voltage
- V_{TH-} : Negative Threshold Voltage
- V_{OH} : Output Voltage at High
- V_{OL} : Output Voltage at Low
- V_H : Hysteresis Voltage

Since LMV321/LMV358/LMV324 have rail-to-rail output, the $(V_{OH} - V_{OL})$ is equal to V_S , which is the supply voltage.

$$V_H = V_S/(1+R_2/R_1)$$

The differential voltage at the input of the op amp should not exceed the specified absolute maximum ratings. For real comparators that are much faster, we recommend you use National's LMV331/LMV93/LMV339, which are single, dual and quad general purpose comparators for low voltage operation.

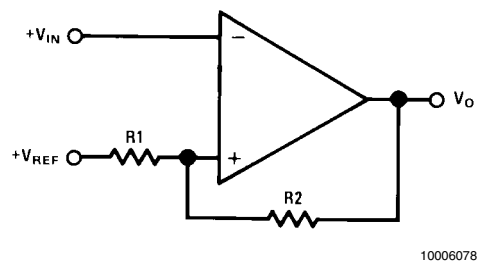
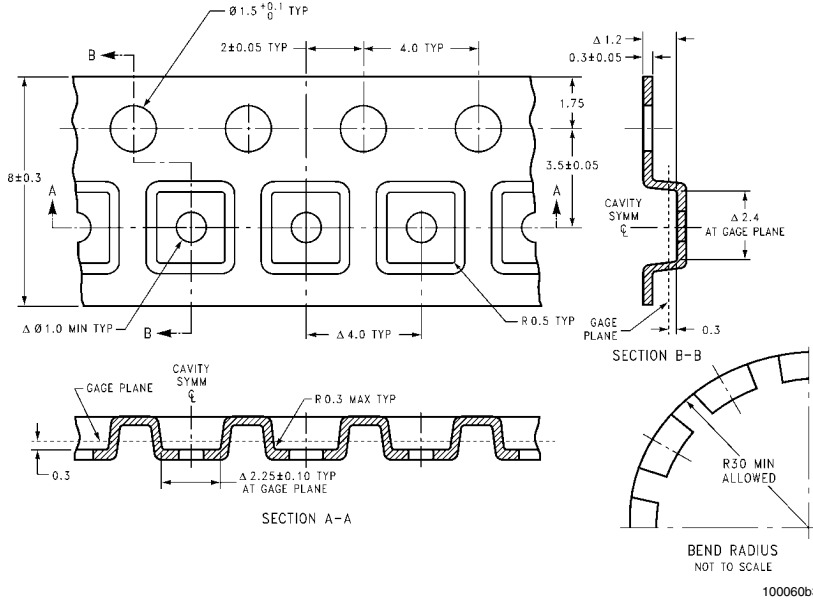

FIGURE 24. Comparator with Hysteresis

SC70-5 Tape and Reel Specification



SOT-23-5 Tape and Reel Specification

TAPE FORMAT

Tape Section	# Cavities	Cavity Status	Cover Tape Status
Leader (Start End)	0 (min)	Empty	Sealed
	75 (min)	Empty	Sealed
Carrier	3000	Filled	Sealed
	250	Filled	Sealed
Trailer (Hub End)	125 (min)	Empty	Sealed
	0 (min)	Empty	Sealed

TAPE DIMENSIONS

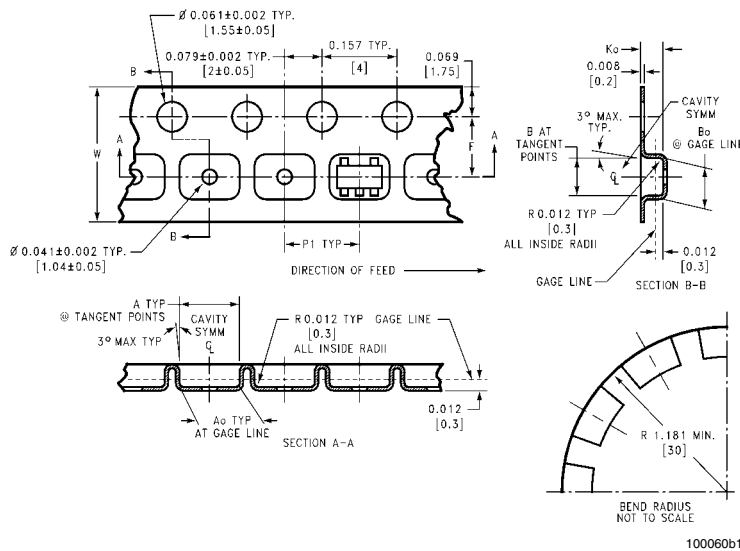

8 mm	0.130 (3.3)	0.124 (3.15)	0.130 (3.3)	0.126 (3.2)	0.138 ±0.002 (3.5 ±0.05)	0.055 ±0.004 (1.4 ±0.11)	0.157 (4)	0.315 ±0.012 (8 ±0.3)
Tape Size	DIM A	DIM Ao	DIM B	DIM Bo	DIM F	DIM Ko	DIM P1	DIM W

REEL DIMENSIONS

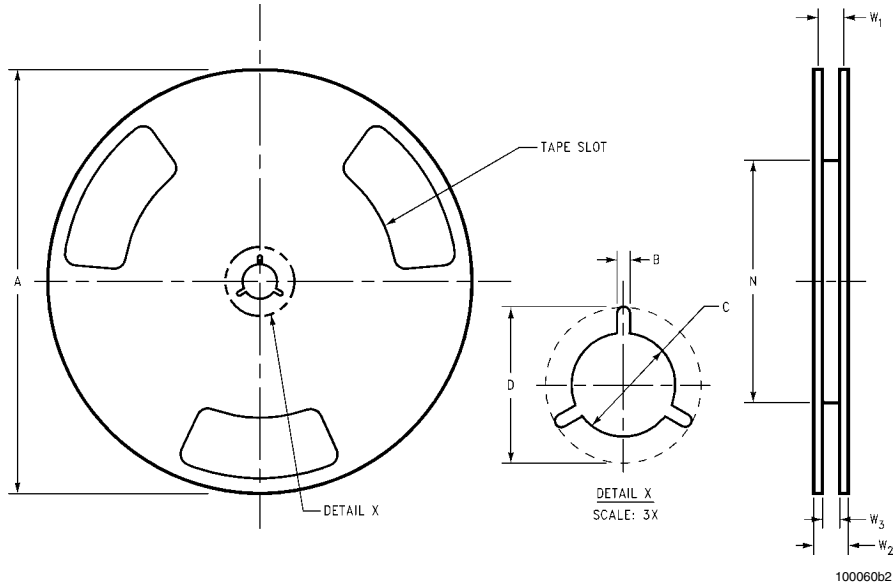

8 mm	7.00 330.00	0.059 1.50	0.512 13.00	0.795 20.20	2.165 55.00	0.331 + 0.059/-0.000 8.40 + 1.50/-0.00	0.567 14.40	W1 + 0.078/-0.039 W1 + 2.00/-1.00
Tape Size	A	B	C	D	N	W1	W2	W3

Physical Dimensions inches (millimeters) unless otherwise noted

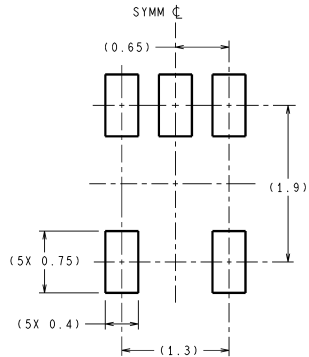
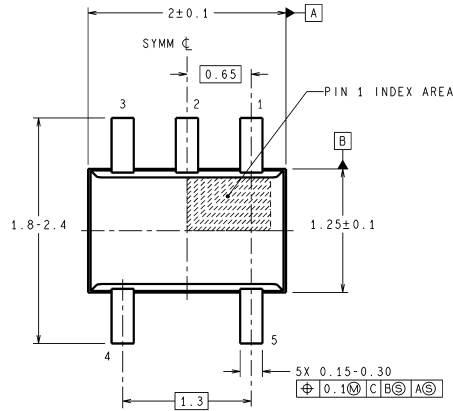

LAND PATTERN RECOMMENDATION

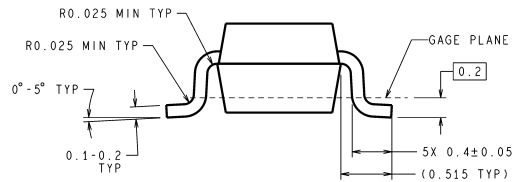
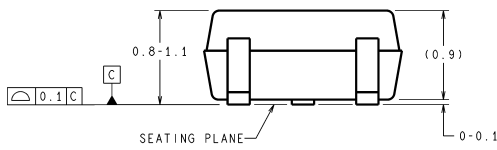

DIMENSIONS ARE IN MILLIMETERS
DIMENSIONS IN () FOR REFERENCE ONLY

MAA05A (Rev D)

5-Pin SC70
NS Package Number MAA05A

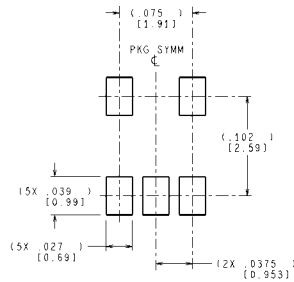
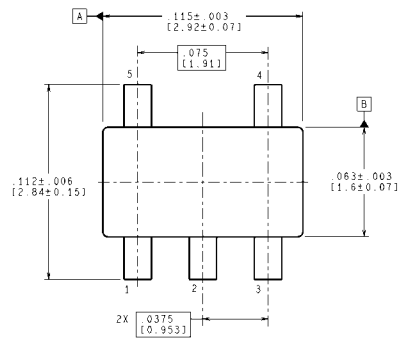

LAND PATTERN RECOMMENDATION

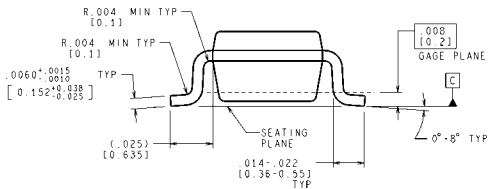
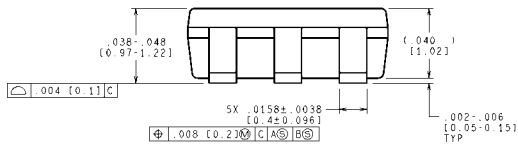

CONTROLLING DIMENSION IS INCH
VALUES IN () ARE MILLIMETERS
DIMENSIONS IN () FOR REFERENCE ONLY

MF05A (Rev C)

5-Pin SOT23
NS Package Number MF05A

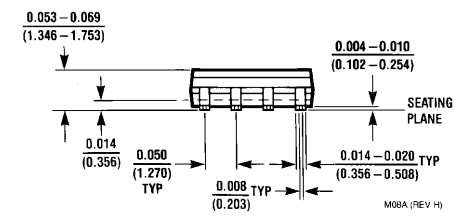
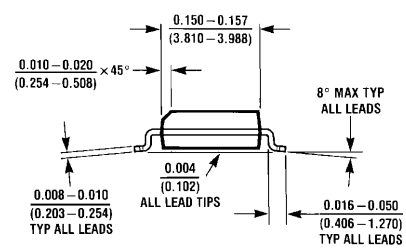
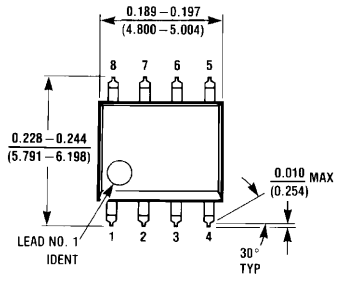

8-Pin SOIC
NS Package Number M08A

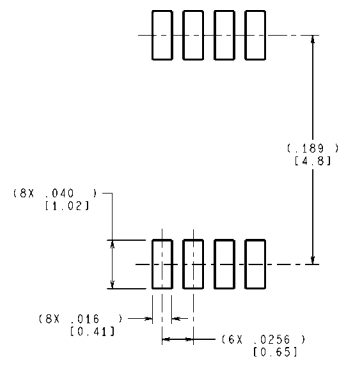
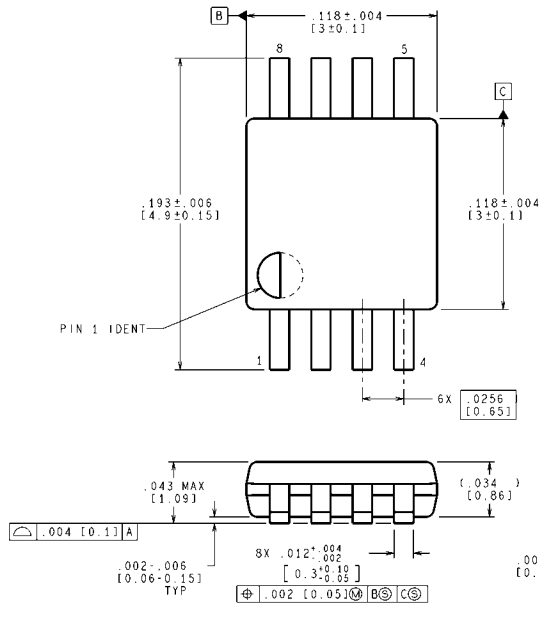

LAND PATTERN RECOMMENDATION

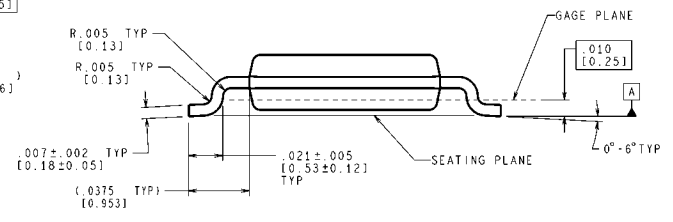

CONTROLLING DIMENSION IS INCH
VALUES IN [] ARE MILLIMETERS

8-Pin MSOP
NS Package Number MUA08A

MUA08A (Rev E)

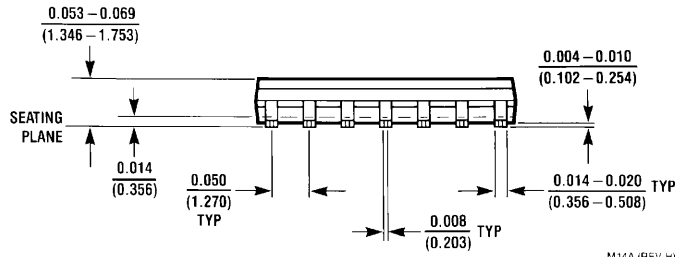
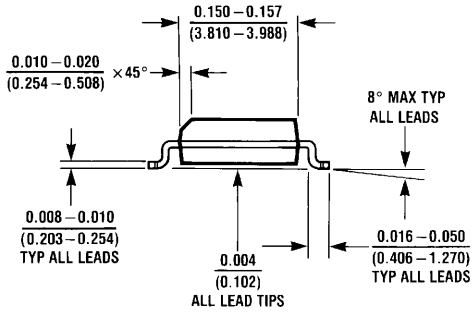
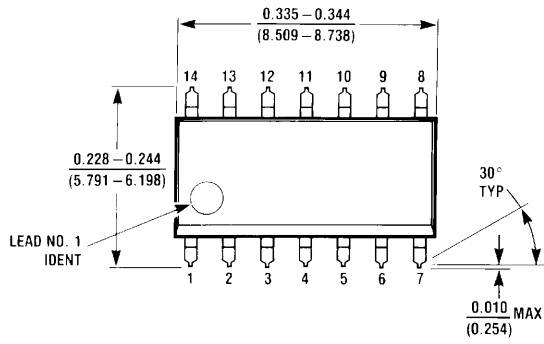

M14A (REV H)

14-Pin SOIC
NS Package Number M14A

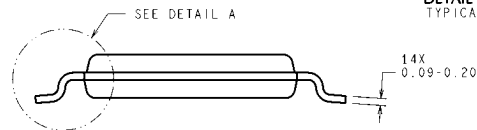
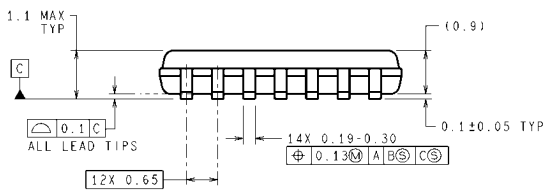
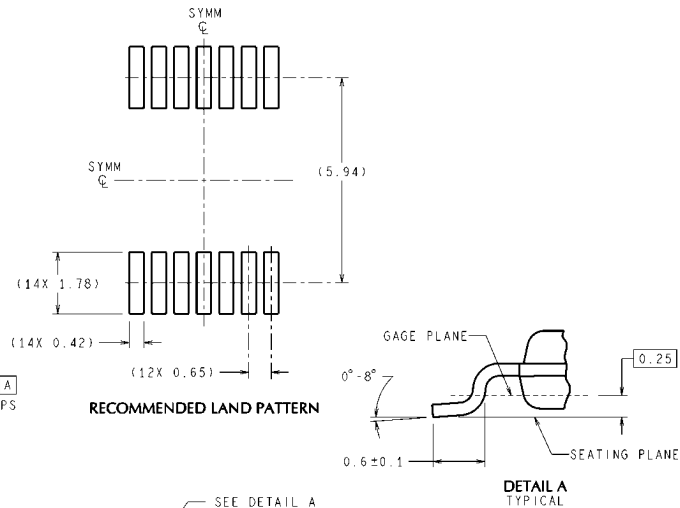
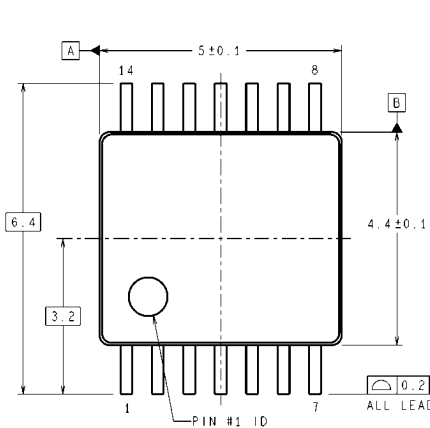

DIMENSIONS ARE IN MILLIMETERS
DIMENSIONS IN () FOR REFERENCE ONLY

MTC14 (Rev D)

14-Pin TSSOP
NS Package Number MTC14

Notes

THE CONTENTS OF THIS DOCUMENT ARE PROVIDED IN CONNECTION WITH NATIONAL SEMICONDUCTOR CORPORATION ("NATIONAL") PRODUCTS. NATIONAL MAKES NO REPRESENTATIONS OR WARRANTIES WITH RESPECT TO THE ACCURACY OR COMPLETENESS OF THE CONTENTS OF THIS PUBLICATION AND RESERVES THE RIGHT TO MAKE CHANGES TO SPECIFICATIONS AND PRODUCT DESCRIPTIONS AT ANY TIME WITHOUT NOTICE. NO LICENSE, WHETHER EXPRESS, IMPLIED, ARISING BY ESTOPPEL OR OTHERWISE, TO ANY INTELLECTUAL PROPERTY RIGHTS IS GRANTED BY THIS DOCUMENT.

TESTING AND OTHER QUALITY CONTROLS ARE USED TO THE EXTENT NATIONAL DEEMS NECESSARY TO SUPPORT NATIONAL'S PRODUCT WARRANTY. EXCEPT WHERE MANDATED BY GOVERNMENT REQUIREMENTS, TESTING OF ALL PARAMETERS OF EACH PRODUCT IS NOT NECESSARILY PERFORMED. NATIONAL ASSUMES NO LIABILITY FOR APPLICATIONS ASSISTANCE OR BUYER PRODUCT DESIGN. BUYERS ARE RESPONSIBLE FOR THEIR PRODUCTS AND APPLICATIONS USING NATIONAL COMPONENTS. PRIOR TO USING OR DISTRIBUTING ANY PRODUCTS THAT INCLUDE NATIONAL COMPONENTS, BUYERS SHOULD PROVIDE ADEQUATE DESIGN, TESTING AND OPERATING SAFEGUARDS.

EXCEPT AS PROVIDED IN NATIONAL'S TERMS AND CONDITIONS OF SALE FOR SUCH PRODUCTS, NATIONAL ASSUMES NO LIABILITY WHATSOEVER, AND NATIONAL DISCLAIMS ANY EXPRESS OR IMPLIED WARRANTY RELATING TO THE SALE AND/OR USE OF NATIONAL PRODUCTS INCLUDING LIABILITY OR WARRANTIES RELATING TO FITNESS FOR A PARTICULAR PURPOSE, MERCHANTABILITY, OR INFRINGEMENT OF ANY PATENT, COPYRIGHT OR OTHER INTELLECTUAL PROPERTY RIGHT.

LIFE SUPPORT POLICY

NATIONAL'S PRODUCTS ARE NOT AUTHORIZED FOR USE AS CRITICAL COMPONENTS IN LIFE SUPPORT DEVICES OR SYSTEMS WITHOUT THE EXPRESS PRIOR WRITTEN APPROVAL OF THE CHIEF EXECUTIVE OFFICER AND GENERAL COUNSEL OF NATIONAL SEMICONDUCTOR CORPORATION. As used herein:

Life support devices or systems are devices which (a) are intended for surgical implant into the body, or (b) support or sustain life and whose failure to perform when properly used in accordance with instructions for use provided in the labeling can be reasonably expected to result in a significant injury to the user. A critical component is any component in a life support device or system whose failure to perform can be reasonably expected to cause the failure of the life support device or system or to affect its safety or effectiveness.

National Semiconductor and the National Semiconductor logo are registered trademarks of National Semiconductor Corporation. All other brand or product names may be trademarks or registered trademarks of their respective holders.

Copyright© 2007 National Semiconductor Corporation

For the most current product information visit us at www.national.com



National Semiconductor Americas Customer Support Center
Email: new.feedback@nsc.com
Tel: 1-800-272-9959

National Semiconductor Europe Customer Support Center
Fax: +49 (0) 180-530-85-86
Email: europe.support@nsc.com
Deutsch Tel: +49 (0) 69 9508 6208
English Tel: +49 (0) 870 24 0 2171
Français Tel: +33 (0) 1 41 91 8790

National Semiconductor Asia Pacific Customer Support Center
Email: ap.support@nsc.com

National Semiconductor Japan Customer Support Center
Fax: 81-3-5639-7507
Email: jpn.feedback@nsc.com
Tel: 81-3-5639-7560